

SGM[®] LP-700
LED PIXEL

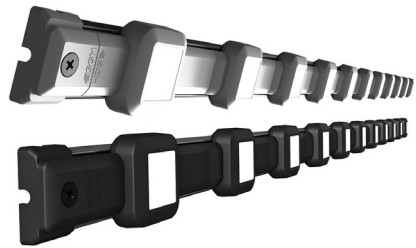

LP-700 LED PIXEL USER MANUAL REV. 1

© 2012 SGM™. Information subject to change without notice. SGM and all affiliated companies disclaim liability for any injury, damage, direct or indirect loss, consequential or economic loss or any other loss occasioned by the use of, inability to use or reliance on the information contained in this manual. The SGM logo, the SGM name and all other trademarks in this document pertaining to services or products by SGM or its affiliates and subsidiaries are trademarks owned or licensed by SGM or its affiliates or subsidiaries.

This edition applies to firmware version 1 or later.

English edition

Contents

Dimensions.....	4
Safety information.....	5
Overview.....	6
Installing an LP-700 LED Pixel strip	10
DMX control	12
Service.....	13
Specifications	14

Dimensions

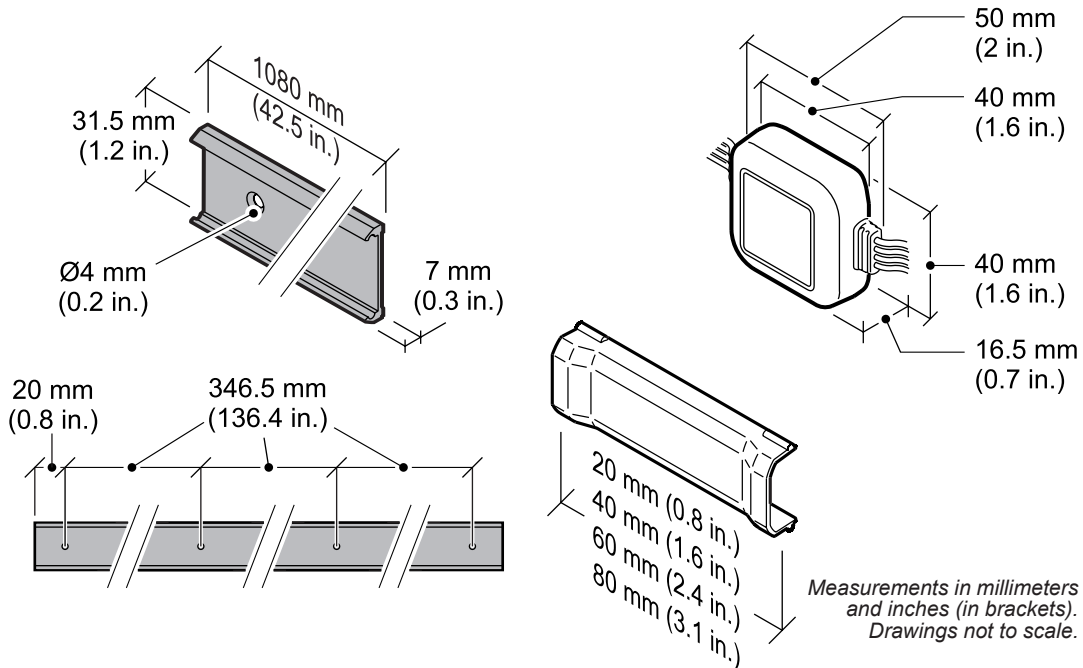

Safety information



WARNING! Read the safety precautions in this section before installing, powering or operating this product.

The LP-700 LED Pixel system is intended for professional use only. It is not suitable for household use.

Review the following safety precautions carefully before installing or operating the device.

- Do not open the device; there are no user-serviceable parts inside.
- Ensure that power is cut off when connecting the device and its power supply unit to the AC mains supply.
- Ensure that the power supply units are electrically connected to earth (ground).
- Do not apply power if the device or mains cable is in any way damaged.
- Do not immerse the fixtures in water or liquid.
- Install only in accordance with applicable building codes.
- Do not paint, cover, or modify the device, and do not filter or mask the light.
- Installation must be performed by a qualified electrician.
- Use only IP65-rated connectors for outdoor installations.

Overview

The LP-700 LED Pixel system is a rail-mounted, DMX-controllable, pixel-effect light strip incorporating pixels with red, green & blue (RGB) color mixing. These strips are IP65-rated and are designed for permanent indoor or outdoor installation. LED Pixels are ideal for pixel arrays or similar daisy-chained arrays of multiple DMX controllable effect fixtures. LP-700 LED Pixels have an LED life expectancy of 50,000 hours.

Each strip contains 56 LP-700 LED Pixels, but can be cut or spliced to the appropriate length. When installed on the supplied rails, a pixel array can be installed with a pitch of 60, 80, 100 or 120 mm (2.4, 3.1, 3.9 or 4.7 in.). (*Pitch* is the distance from the center of one pixel to the center of the next pixel.) LP-700 LED Pixels are DMX-controllable and self-addressing, with up to 168 individual pixels being able to be controlled using a single DMX universe.

Preparing for installation

Each LP-700 LED Pixel strip—or any length of up to 56 pixels—must be connected to an LP-700 *power supply unit* (P/N 83061701). The first strip, or up to 56 pixels, is connected to mains supply and a DMX-compatible control device (not supplied) using an LP-700 Injector (P/N 83062007). After 56 pixels, the power supply must be boosted by connecting an additional power supply unit (P/N 83061701) that is connected to mains supply, using an LP-700 Power Injector (P/N 83062008); DMX control is passed from one strip to the next, via the Power Injector.

The maximum cabled-distance between a power supply unit and the first LP-700 LED Pixel that it supplies power to is 3 metres (10 feet).

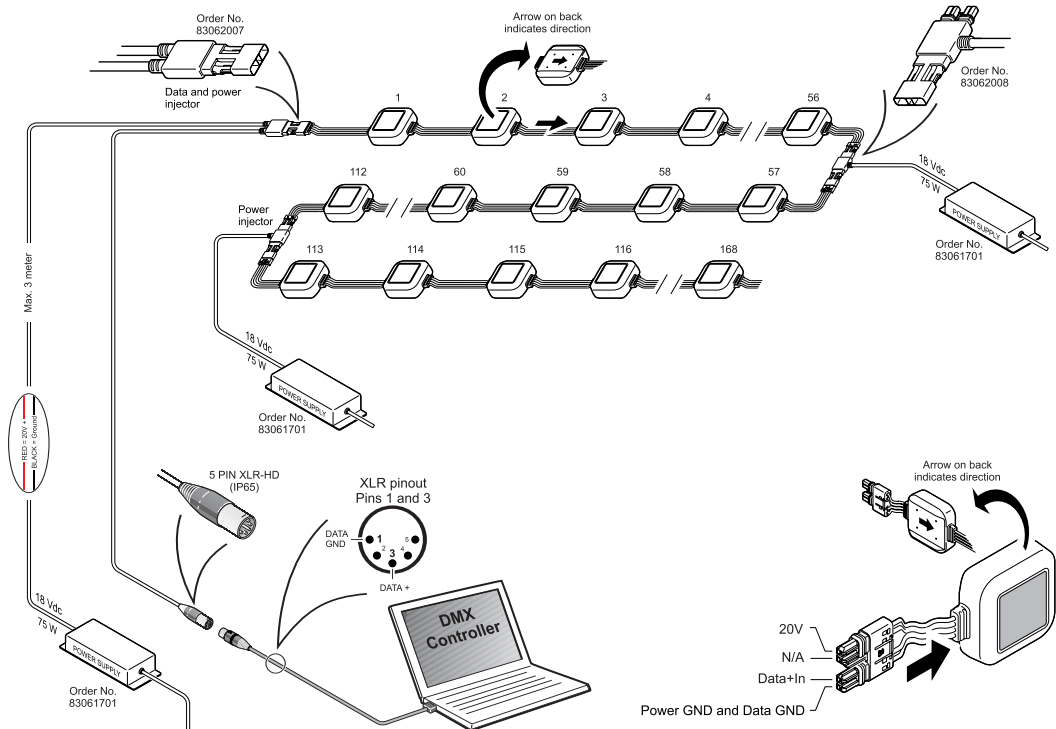

The maximum number of LP-700 pixels in a controllable daisy chain is 168 (on a single DMX universe). Additional LED Pixels can be controlled in an installation using multiple DMX universes and separate daisy chains, each chain with its own Power Injector and up to 168 pixels. Each pixel uses three DMX control channels, and the maximum number of channels in a DMX universe is 512 (3 x 168=504 channels). Use only IP65-rated connectors for outdoor installations.

Power supply unit

The LP-700 power supply unit (transformer) can operate on any 100–240 V, 50/60 Hz AC mains power supply and supplies 18 V DC to LP-700 LED Pixels via an Injector (for the first power supply in a daisy chain of LED Pixels - P/N 83062007) or power injector (for subsequent booster power supplies in a daisy chain of LED Pixels - P/N 83062008). Splicing or connecting a power supply unit to mains supply, or to an injector or power injector, must be carried out by a qualified electrician.

Power supply units must be grounded/earthed and be able to be isolated from AC power. The AC power supply must incorporate a fuse or circuit breaker for fault protection.

Do not open a power supply unit to replace the supplied power cable, or connect the device to an electrical dimmer system, as this can damage it.

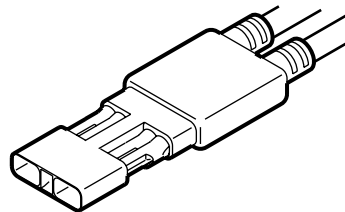

Injector (power & DMX)

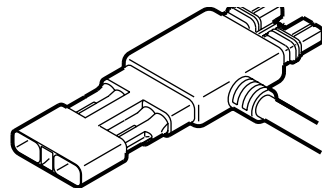

*Power Injector
(power & DMX-through)*

Boosting power using an additional power supply unit and a power injector

Always ensure that power is boosted after every 56 pixels in a daisy-chain. An LP-700 Power Injector (P/N 83062008) can be used to supply boost power from an additional power supply unit (PSU - P/N 83061701) and connect two LP-700 LED Pixel strips without splicing or crimping; the DMX control signal continues unbroken to each fixture in a daisy chain. A 3-metre (10 ft) maximum cabled-distance between the power supply and the first LED Pixel it supplies power to applies.

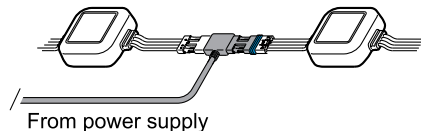

Cutting or splicing strips

Strips can be cut to the required length, but if the system is installed outdoors, ensure that any exposed cable ends are sealed using a hot glue gun, or similar IP65-rated cable sealing method. Splicing strips of LP-700 LED Pixels together must be carried out by a qualified electrician. The arrow on the back of each LP-700 LED Pixel indicates the direction away from the power supply unit.

When and patching, splicing or crimping power and control cables it is important to note that the LP-700 LED Pixel uses *unbalanced* DMX. DMX control only uses pins 1 and 3 of the XLR connectors. The pinout of the male connectors on the LP-700 LED Pixel strips are shown here in the illustration.

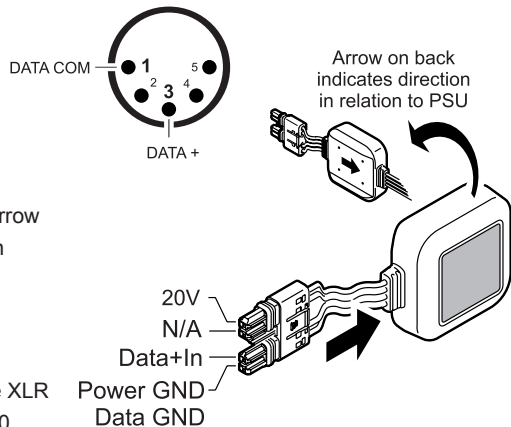

Installing an LP-700 LED Pixel strip

The LP-700 system can be installed in any orientation.

1. Affix each rail to a flat surface using 4 mm (0.2 in.) countersunk screws. The distance between the center of parallel rails is the pitch distance.

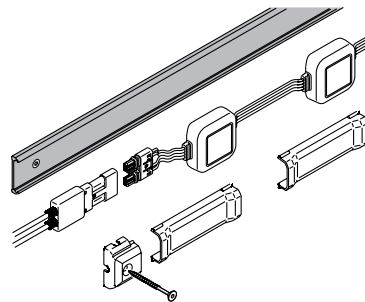
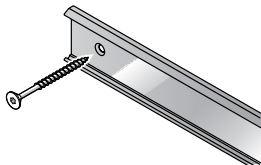

The distance between pixels (*pitch*) on a single strip is also determined by the width (L) of cover that is inserted between each pixel on the strip. Covers are available in four lengths:

Width (L)	Pitch
20 mm (0.8 in.)	60 mm (2.4 in.)
40 mm (1.6 in.)	80 mm (3.1 in.)
60 mm (2.4 in.)	100 mm (3.9 in.)
80 mm (3.1 in.)	120 mm (4.7 in.)

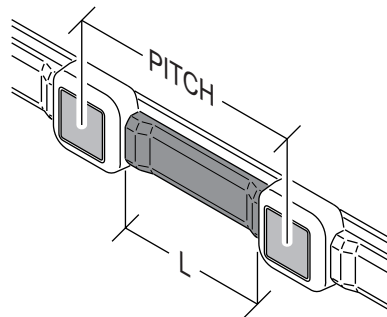

- Place the LP-700 LED Pixel strip on the rail. Note that the arrow on the back of each pixel indicates the direction away from the power supply.
- Affix the LED Pixel strip by placing a cover over the cable between two pixels on the rail and pressing until you hear an audible “click”. Any excess cable can be folded under the pixel.
- Place a cover between each pixel on the rail to ensure that the pitch is maintained and to hold the LP-700 LED Pixel strip in place.
- Place end caps at each end of the rail. Two types are available: the first is secured using a 4 mm (0.2 in.) countersunk screw, while the second type can be secured using a contact adhesive.

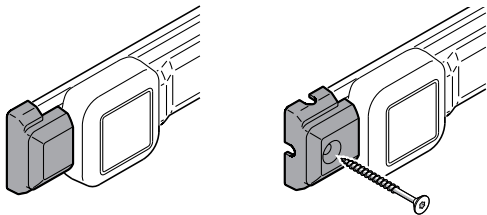

- Ensure that any wires from the power supply are threaded through the holes provided. Any extra cable at the end of a rail can be folded back under the last LED Pixel.

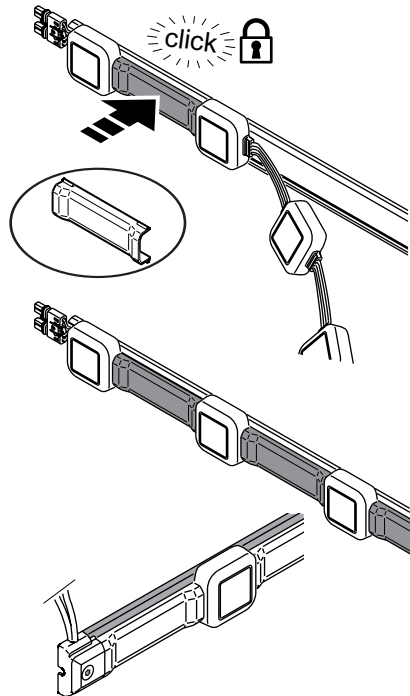
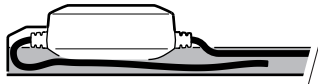

DMX control

LP-700 LED Pixels can be controlled using any DMX512-compatible DMX controller that supports the size of your installation. We recommend the use of a controller that has pixel mapping functionality.

About DMX

Each individual LP-700 LED Pixel can be controlled using signals sent by a DMX controller over three

channels. The first channel used to receive data from a DMX control device is known as the DMX address. Each LP-700 LED Pixel sets its own DMX address automatically. The first LP-700 LED Pixel is set to DMX address '1', and the next pixel sets itself to '4', and so on in increments of three channels per pixel. For example, if an LP-700 LED Pixel has a DMX address of 7, then it uses channels 7, 8 and 9. The following pixel in the DMX chain will have a DMX address of 10. It is not possible to otherwise manually set or force the DMX address of an individual LP-700 LED Pixel.

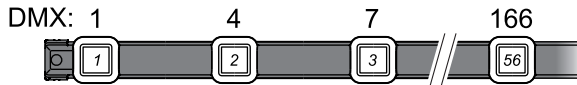

DMX protocol

LP-700 LED Pixel - 3 channel DMX - RGB			
Channel	Value	Percent	Function
1	0-255	0-100	Red 0-100%
2	0-255	0-100	Green 0-100%
3	0-255	0-100	Blue 0-100%

Service

There are no user-serviceable components in these devices.

Do not open any of the parts in the LP-700 system, as doing so is likely to cause damage.

Consult your SGM dealer if the device operates abnormally, is defective or otherwise in need of service or repair. Visit <http://www.sgmlight.com> for contact information.

Specifications

PHYSICAL - LP-700 LED PIXEL

LED Pixel length x depth x height.....	40 x 40 x 16.5 mm (1.6 x 1.6 x 0.7 in.)
Number of pixels per LED pixel strip	56
LED Pixel strip length	6.8 m (21.1 ft)

PHYSICAL - LP-700 LED PIXEL RAIL

Length x depth x height	1080 x 7 x 31.5 mm (42.5 x 0.3 x 1.2 in.)
Mounting holes	Ø 4 mm (0.2 in.)

PHYSICAL - LP-700 LED PIXEL COVERS

Width	Option of 20, 40, 60 or 80 mm (0.8, 1.6, 2.4 or 3.1 in.)
-------------	----------------------------------------------------------

PHYSICAL - LP-700 POWER SUPPLY

Length x width x height.....	185 x 62.5 x 40.5 mm (7.3 x 2.5 x 1.6)
------------------------------	----------------------------------------

LIGHT SOURCE

Pixel illumination source	4 x RGB SMD LED
Expected LED lifetime (at 70% luminous output)	50,000 hours

* Specifications subject to change without notice

CONNECTIONS - LP-700 INJECTOR

DMX control 5-pin XLR male input

INSTALLATION

Orientation Any

Pixel pitch 60, 80, 100 or 120 mm (2.4, 3.1, 3.9 or 4.7 in.)

Maximum cabled-distance from power supply unit to first LP-700 LED Pixel 3 metres (10 feet)

OPERATING CONDITIONS

Ambient temperature range (T_a) -40° to 50° C (-40° to 122° F)

Maximum relative humidity 100%

IP-rating IP 65

PROGRAMMING AND CONTROL

Control interface Unbalanced USITT DMX 512-A

DMX channel requirements 3 channels per LP-700 LED Pixel (self-addressing)

LP-700 POWER SUPPLY ELECTRICAL

DC power out 18 V, 75 W

AC mains power in 100-240 VAC nominal

Output current 3.75 A

ORDERING INFORMATION

LP-700 Power Supply Unit	P/N 83061701
LP-700 Injector (DMX & power).....	P/N 83062007
LP-700 Power Injector	P/N 83062008



SGM A/S · Soeren Frichs Vej 51-53 · DK 8230 Aabyhoej · Denmark
Tel +45 70 20 74 00 · info@sgmlight.com · www.sgmlight.com